



RowFlow Liquid Manual





Precision Planting, Inc.

23207 Townline Road Tremont, IL 61568
ph. (309) 925-5050 fax. (309) 925-5029
info@precisionplanting.com
2020support@precisionplanting.com

Precision Planting Warranty & Liability Policy (Revision effective 7-1-10)

Warranties, Disclaimers, and Limitation of Remedies:

These terms and conditions represent the entire agreement between the parties hereto and there are no collateral, oral, or other agreements or understandings, unless expressly stipulated.

Precision Planting warrants that all Precision Planting products, equipment and merchandise are free from defects in material and workmanship. The term of the express warranty recited herein shall be limited to one (1) year from the date of sale by Precision Planting. This warranty shall only extend to the dealer if this warranty is properly presented to Customer. With respect to 20/20 SeedSense, AirForce and RowFlow, the express warranty recited herein shall only apply if such products are properly registered by the Customer.

These terms and conditions represent the entire agreement between the parties hereto and there are no collateral, oral, or other agreements or understandings, unless expressly stipulated.

The express warranty recited herein does not extend to any costs or damages other than one of the following, which Precision Planting shall elect at its sole discretion: replacement, repair, or refund of the purchase price. Precision Planting makes no other warranty of any kind whatsoever, express or implied.

ANY EXPRESS OR IMPLIED WARRANTIES OF MERCHANTABILITY OR FITNESS FOR A PARTICULAR PURPOSE ARE HEREBY DISCLAIMED BY PRECISION PLANTING. THERE ARE NO WARRANTIES THAT EXTEND BEYOND THE DESCRIPTION ON THE FACE HEREOF.

Precision Planting is NOT LIABLE FOR CONSEQUENTIAL DAMAGES of any nature whatsoever, including without limitation lost yield, replanting cost, supplies or other expenses. Precision Planting is NOT LIABLE FOR INCIDENTAL DAMAGES of any nature whatsoever, including without limitation diagnostic and installation expenses, travel expenses, and shipping expenses. The limitations of remedy recited herein apply to any action by the Customer whether or not such action is based in warranty.

Some states or jurisdictions do not allow the exclusion or limitation of implied warranties, incidental damages or consequential damages; so the above limitations or exclusions may not apply to you.

Liability:

Customer assumes all liability for damages from accidents caused by or incurred in the use of transportation of said equipment. Customer agrees to indemnify and hold harmless the said Precision Planting, its officers, agents, and employees from any and all damages and/or liability to any person whomsoever arising out of or resulting from the use, storage, or transportation of said equipment by the Customer or anyone else while the equipment is in the custody of the Customer. The Customer acknowledges receipt of the equipment in good working condition and repair. In the event of any accident involving said equipment, Customer shall promptly furnish to Precision Planting a complete report in writing, with names and addresses of witnesses and parties involved and Customer shall make all reports required by law. Customer agrees to review and follow any published safety instructions in the product manual.

Notice of Non-Waiver:

The failure by Precision Planting, at any one or more time, to insist upon the strict performance by the Customer of the covenants, conditions and/or terms of this agreement, shall not be construed as a waiver of Precision Planting's right to demand strict compliance with and performance of all covenants, conditions and/or terms hereof. Notice of demand for strict compliance is hereby waived by the Customer, and time is expressly made of the essence of this agreement.

Choice of Law:

Any dispute or claim arising from or related to this Policy, or related to a product governed by this Policy, shall be governed by the laws of the State of Illinois.

Safety Information



Always wash your hands after working on or around agricultural equipment prior to eating, drinking, smoking, chewing, etc...



Always use the proper Personal Protective Equipment (PPE) for any task.

Examples include: Gloves when handling sharp or abrasive materials
Eye protection when handling contents or systems under pressure (ie. Hydraulic, Pneumatic, Water)
Welding helmet, Welding gloves, and welders clothing when welding/torching



Prior to working under or at ground level of any equipment secure the machinery from movement; accidental user operation or simple rolling of equipment. This should involve Lock-Out tags at the battery, removal of the Ignition key, "Do Not Operate" signs placed at key locations, as well as wheel chocks as necessary.



When working on a vehicle or implement's hydraulic system, suspended components may suddenly drop. If you are working on or around the implement at this time serious injury could result. If possible lower the implement or attachment to the ground before beginning any work. Alternatively; use mechanical lock-up devices to secure any components in their lifted positions.



Agricultural equipment may have been exposed to many types of chemicals. Any chemicals or residues should be removed from the planter prior to beginning work. Obey all existing (new & original) warning signs and caution labels on all equipment.



When working on or around equipment that has been or is running many components may get extremely hot. To avoid injury &/or serious burns allow all equipment components to properly cool before working on or around them.



Avoid wearing loose or ragged clothing or jewelry around equipment, with special attention to avoid moving parts.



Route and secure all wires and connections to avoid crimping or damaging. This may result in unexpected shortages and shocks.



Use extreme caution when working on pressurized systems (Air, Water, Oil). Relieve all pressure from a system before disconnecting lines, fittings, etc... Use a cloth or other obstruction to divert possible spray when disconnecting hose connections, fittings, fill caps, breathers, etc. Always use gloves, NEVER use bare hands. To locate or check for leaks use cardboard, never your hand.



Electrical components and devices may contain high voltages and should be kept dry and closed. There are no serviceable components in this unit. Do not open this display unit, the AirForce Module, Row Flow Module, or the Smart Connector. Opening of the covers should be done by, or with guidance from trained personnel.

System Overview

Planter Starter Application

The RowFlow Liquid system will consist of at least four parts to be added to an existing RowFlow system (see RowFlow Installation Guide for information on the RowFlow base system) for planter starter application. These parts include: a Pressure Sensor, a Flow Meter, a Pressure Sensor Harness, and a Flow Meter Harness. Other parts that are required, but may already be installed, are a PWM controlled hydraulic motor to run the liquid pump with a compatible harness and a height sensor.

Note: Liquid pump **must** be a positive displacement pump (ex. piston, diaphragm, roller, and squeeze). Centrifugal pumps are **not** compatible with RowFlow Liquid.

Pressure Sensor

727301



The Pressure Sensor measures the pressure per square inch (psi) of the liquid within the system and to notify the user of this pressure. It will need to be installed inline somewhere between the pump and the row application. The exact location of installation between the two is not critical, but different pressures could be measured at different points in the liquid system. The sensor will measure only the pressure at the point that it is installed. The Pressure Sensor will be connected to the Pressure Sensor Harness.

Pressure Sensor Harness

727302



The Pressure Sensor Harness connects the Pressure Sensor (3-pin Packard Metripack) to the RowFlow system through the Row Unit Module's (RUM) auxiliary port (6-pin Deutsch).

System Overview

Flow Meter

727305 & 727306



The Flow Meter measures the rate at which the liquid is flowing through the system and is used to indicate the application rate of the product. The Flow Meter should be installed **vertically** inline between the liquid pump and distribution. This placement ensures that the rate indicated to the user is for that of the entire system. The sensor on the Flow Meter will be connected to the Flow Meter Harness. There are two Flow Meters available. The Standard Flow (**727306**) is for rates of 2 – 40 gpm, and the Low Flow (**727305**) for rates of .5 – 12 gpm. The Low Flow meter is distinguished with a red zip tie attached.

Flow Meter Harness

727303



The Flow Meter Harness connects the Flow Meter's sensor (3-pin Metripack) to the RowFlow system through the Row Unit Module's (RUM) auxiliary port (6-pin Deutsch).

Sidedress Application

The RowFlow Liquid Sidedress system will consist of one of two harness options. In addition, the system will include two major components of the RowFlow Liquid Planter system. The Pressure Sensor, the Flow Meter and select components of the RowFlow base system will be identified below. Either harness option will require the 20/20 SeedSense Display, SeedSense Tractor Harness, Cab Control Module (CCM), CAN extension, and RowFlow Module (RFM). Also required will be a height sensor and a PWM controlled hydraulic motor to power the liquid pump.

Sidedress Base Harness

727310



The Sidedress Base Harness connects directly to the RFM through the two Cinch connectors on the RFM. This harness connects to the Hydraulic Motor Harness (**727111**), a height sensor or height sensor harness, the 9-pin CAN communication back to the CCM, the Pressure Sensor (**727301**), and the Flow Meter sensor.

Sidedress Sensor Harness

727307



The Sidedress Sensor Harness requires installation with the RowFlow Base Harness (**727011**). This harness will connect to the **Drive Motor 1**, 8-pin Deutsch connection (**NOTE: This harness MUST be connected to Drive Motor 1** connector; it will not function in the other two connectors). The Flow Meter sensor and the Pressure Sensor also connect to this harness. Power for the Pressure Sensor is pulled from the AUX connector (4-pin AMP) on the RF Base Harness. In this setup, the Hydraulic Motor harness (**727111 - MUST** connect into Drive Motor 2 connector) and height sensors will connect through the RowFlow Base Harness.

Installing RowFlow Liquid System (Planter)

Liquid system

Installation of liquid tank, pump, lines, etc. is left to the discretion of the grower.

RowFlow system

Refer to RowFlow Installation Guide to install components of the RowFlow system.

Hydraulic Motor

If installing a new Precision Planting Hydraulic Motor (**727105**), please refer to installation guide included with motor for installation instructions. The motor may be attached to the liquid pump with a direct coupler or a chain & sprocket combination.

Pressure Sensor and Flow Meter

The Pressure Sensor (**727301**) should be installed into a diagnostic "T" (not provided by Precision Planting) somewhere between the liquid pump and the application. Placement of the sensor is not critical. The grower should understand that different pressures can be measured at different points (main line versus individual row line) and where the sensor is installed is the only point at which pressure can be measured. NOTE: Threaded fitting for the Pressure Sensor is ¼" NPT.

The Flow Meter (**727305/727306**) should be installed between the liquid pump and the distribution to the rows. All flow should pass through this meter. The Flow Meter should be installed vertically with approximately six inches before and after that are free of any impediments and sharp objects. There is no specific direction of travel to factor into installation. The green flow sensor threads all the way into the housing and then locked with the jamnut.

NOTE: Thread tape or sealant should be used on all threaded connections, flow meters, and pressure sensors where.

Connecting Components

Identify two Row Unit Modules (RUM) that have open AUX connections (6-pin Deutsch). Other components that may be plugged into the AUX connection could be a Vacuum Sensor, Positive Air Sensor, or a Lift Switch. These will be used to connect the Pressure Sensor and Flow Meter into the system. Connecting the Pressure sensor to a RUM AUX plug will require the use of the 15' Pressure Sensor Harness (**727302**). If additional length is needed, a 12' 6-pin Deutsch extension (**727304**) may be necessary. Connecting the Flow Meter Sensor to a RUM AUX plug will require the use of the 15' Flow Meter Harness (**727303**). If additional length is needed, a 12' 6-pin Deutsch extension (**727304**) may be necessary.

The hydraulic motor harness (**727111** - for the motor driving the liquid pump) may be connected to any of the three Drive Motor (8-pin Deutsch) connections on the RowFlow Base Harness.

Installing RowFlow Liquid System (Planter)

Planter Connection Layout

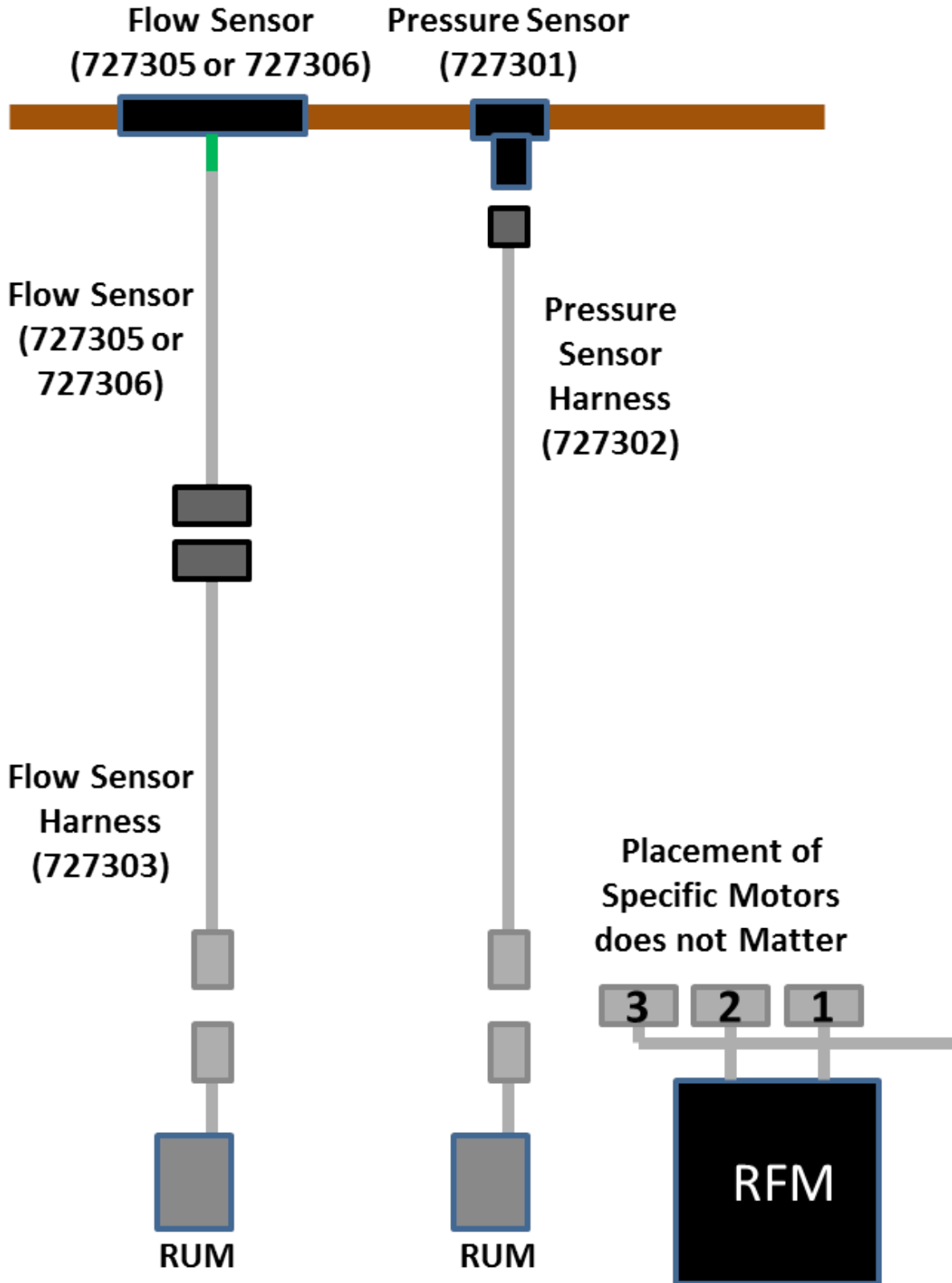

Installing RowFlow Liquid System (Sidedress)

Liquid system

Installation of liquid tank, pump, lines, etc. is left to the discretion of the grower.

RowFlow system

Refer to RowFlow Installation Guide to install components of the RowFlow system. It will be required to have the 20/20 SeedSense Display, Cab Control Module, 20/20 SeedSense Tractor Harness, CAN Extension, and RowFlow Module installed on the tractor & sidedress applicator. A lift switch or height sensor will be necessary for the RowFlow Liquid system to operate. The lift switch or height sensor will either plug into the RowFlow Base Harness (in configurations where this harness is used) or the Sidedress Base Harness.

Hydraulic Motor

If installing a new Precision Planting Hydraulic Motor (**727105**), please refer to installation guide included with motor for installation instructions. The motor may be attached to the liquid pump with a direct coupler or a chain & sprocket combination.

Pressure Sensor and Flow Meter

The Pressure Sensor (**727301**) should be installed into a diagnostic “T” (not provided by Precision Planting) somewhere between the liquid pump and the application. Placement of the sensor is not critical. The grower should understand that different pressures can be measured at different points (main line versus individual row line) and where the sensor is installed is the only point at which pressure can be measured. NOTE: Threaded fitting for the Pressure Sensor is ¼” NPT.

The Flow Meter (**727305/727306**) should be installed between the liquid pump and the distribution to the rows. All flow should pass through this meter. The Flow Meter should be installed vertically with approximately six inches before and after that are free of any impediments and sharp objects. There is no specific direction of travel to factor into installation. The green flow sensor threads all the way into the housing and then locked with the jamnut.

NOTE: Thread tape or sealant should be used on all threaded connections, flow meters, and pressure sensors.

Connecting Components

With Sidedress Base Harness – 727310 – Connect the two Cinch connectors on the Sidedress Base Harness to the RowFlow Module. The Pressure Sensor and Flow Meter Sensor will connect to their respective plugs on the Sidedress Base Harness. Connect the CAN extension from the Cab Control Module to the Sidedress Base Harness and then connect the height sensor harness to the Sidedress Base Harness.

The hydraulic motor harness (for the motor driving the liquid pump) will be connected to the Drive Motor (8-pin Deutsch) connection on the Sidedress Base Harness.

With Sidedress Sensor Harness – 727307 – Connect the 8-pin Deutsch connection to the Drive Motor 1 plug on the RowFlow Base Harness (**MUST** be plugged into Drive Motor 1 plug). The Pressure Sensor and Flow Meter harness will connect to their respective plugs on the Sidedress Sensor Harness. Connect the 4-pin AMP round connector to the AUX plug on the RowFlow Base Harness to pull power for the Pressure Sensor. Height sensor and CAN connection will be made with the RowFlow Base Harness .

The hydraulic motor harness (**727111** - for the motor driving the liquid pump) **MUST** be connected to the Drive Motor 2 (8-pin Deutsch) connection on the RowFlow Base Harness.

Installing RowFlow Liquid System (Sidedress)

Sidedress Connection Layout #1 – Sidedress Base Harness

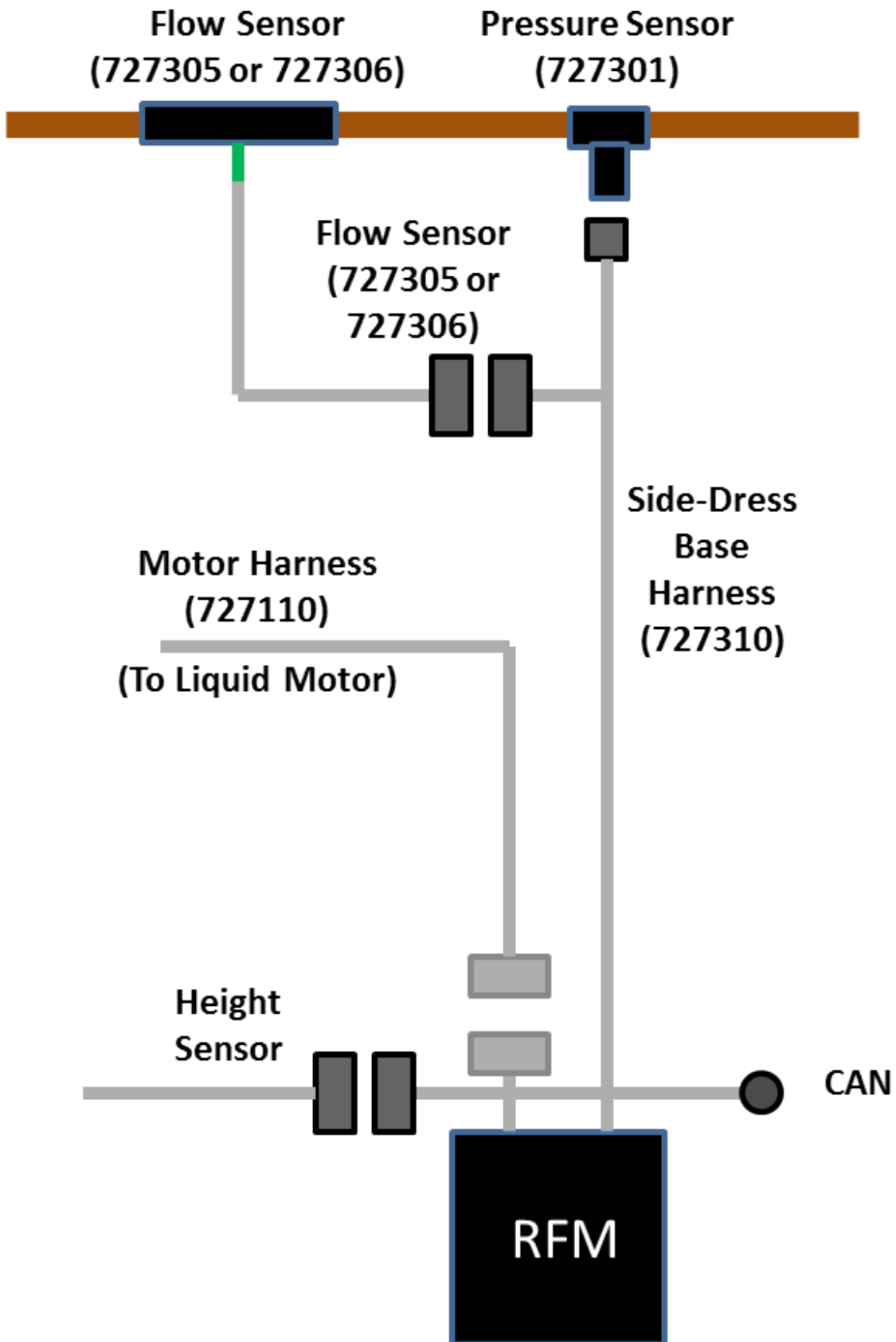

Installing RowFlow Liquid System (Sidedress)

Sidedress Connection Layout #2 – Sidedress Sensor Harness

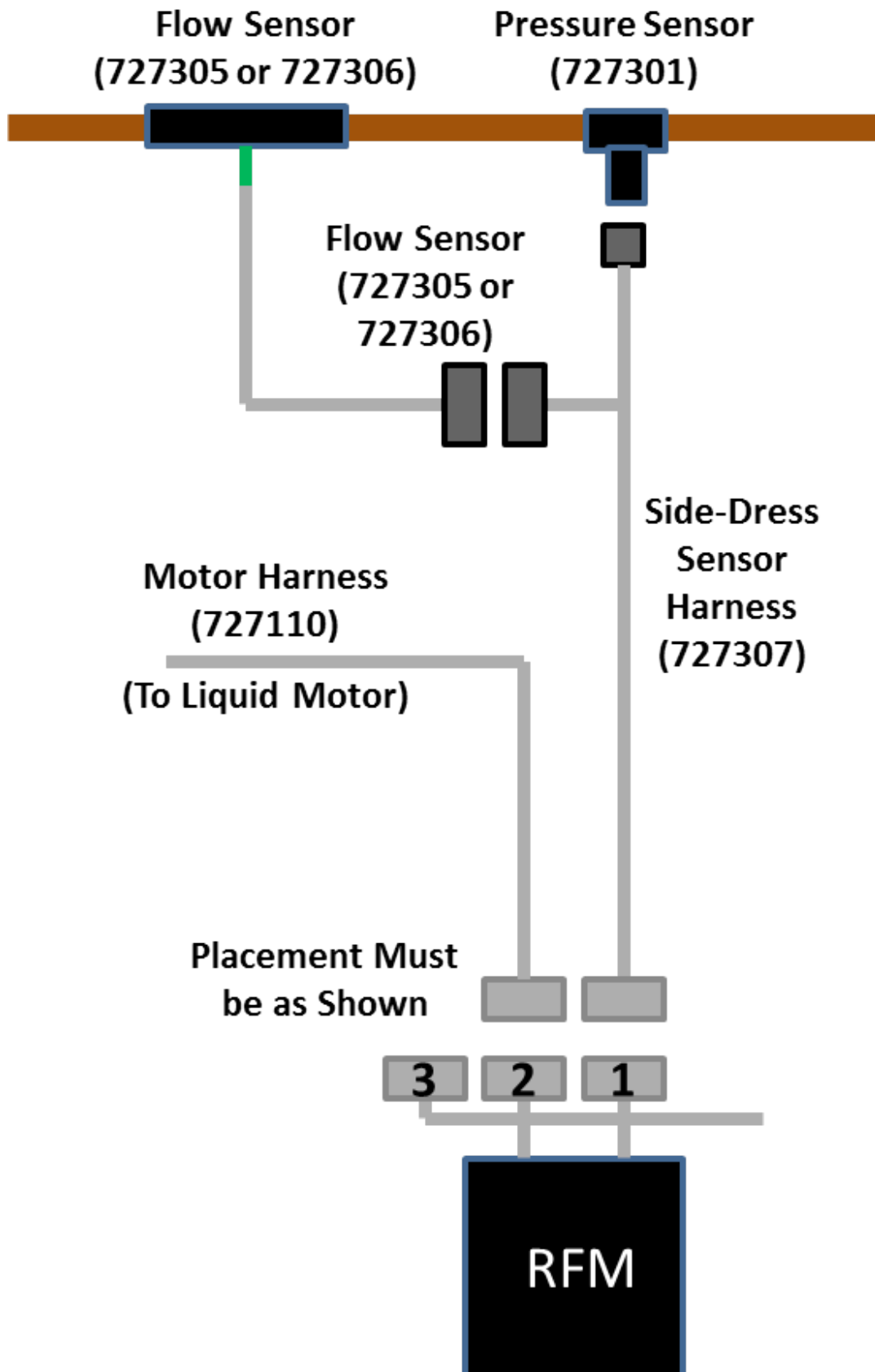

Full System Layouts (Planter)

Planting Layout #1

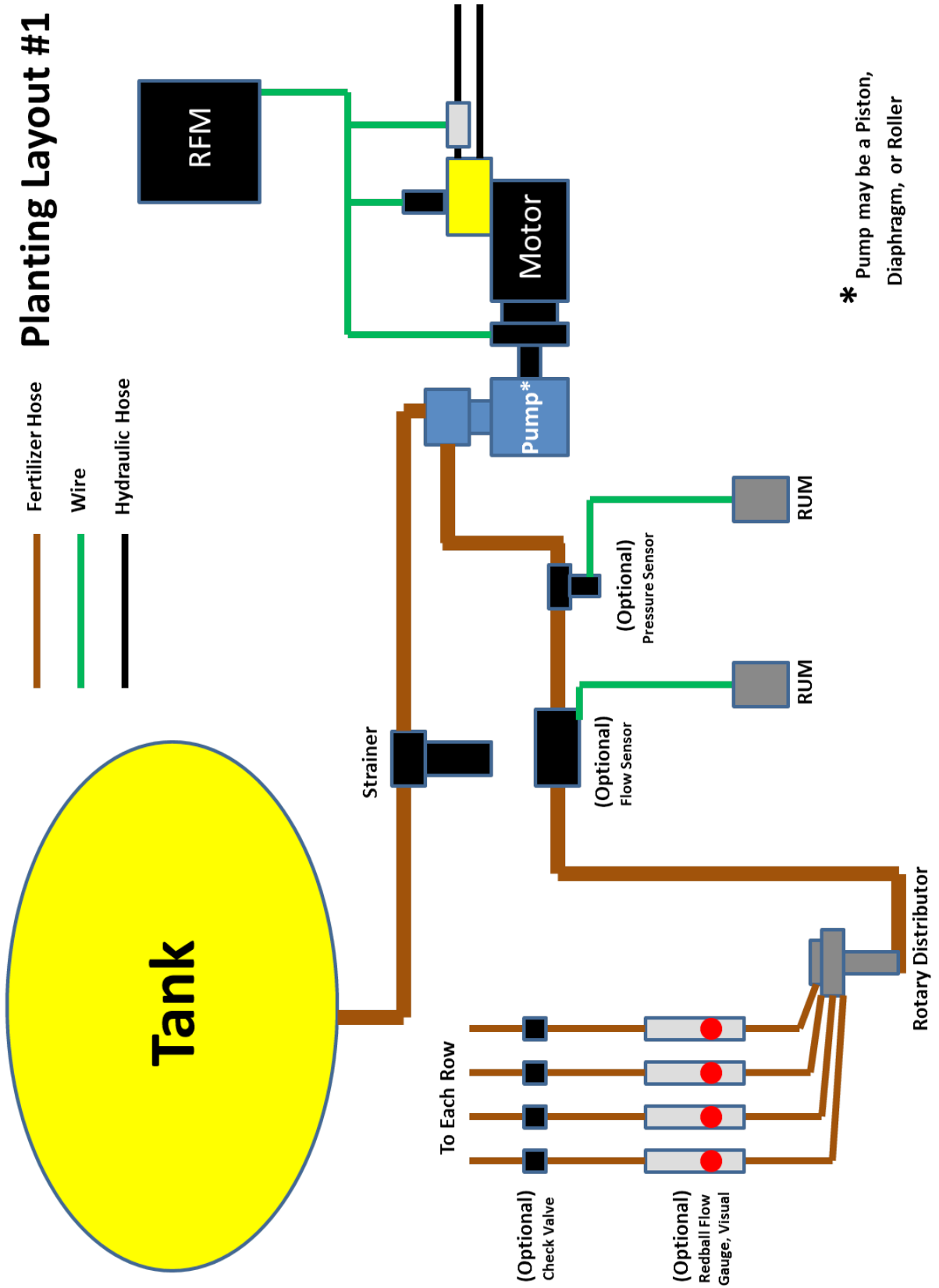

Full System Layouts (Planter)

Planting Layout #2

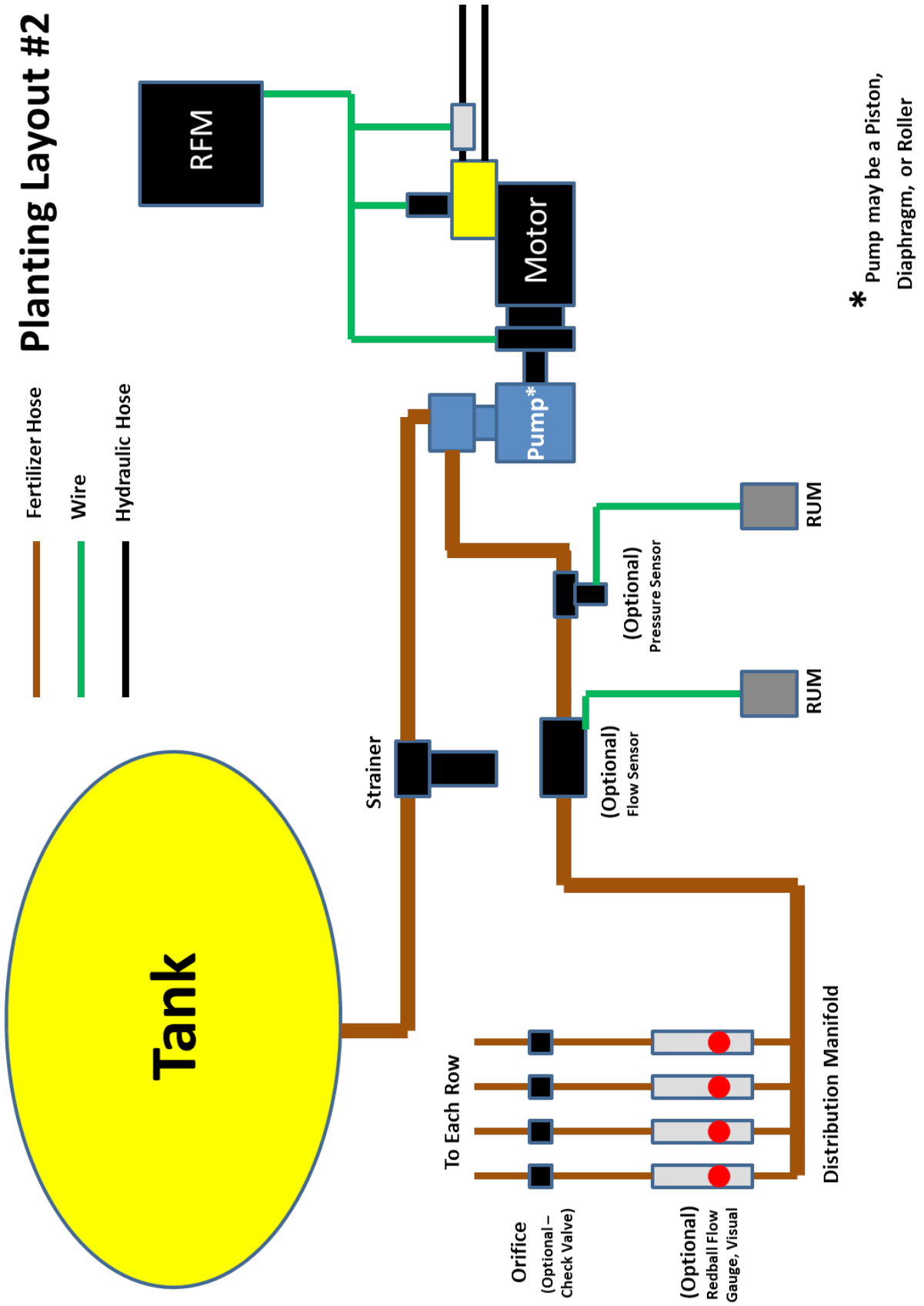

Full System Layouts (Planter)

Planting Layout #3

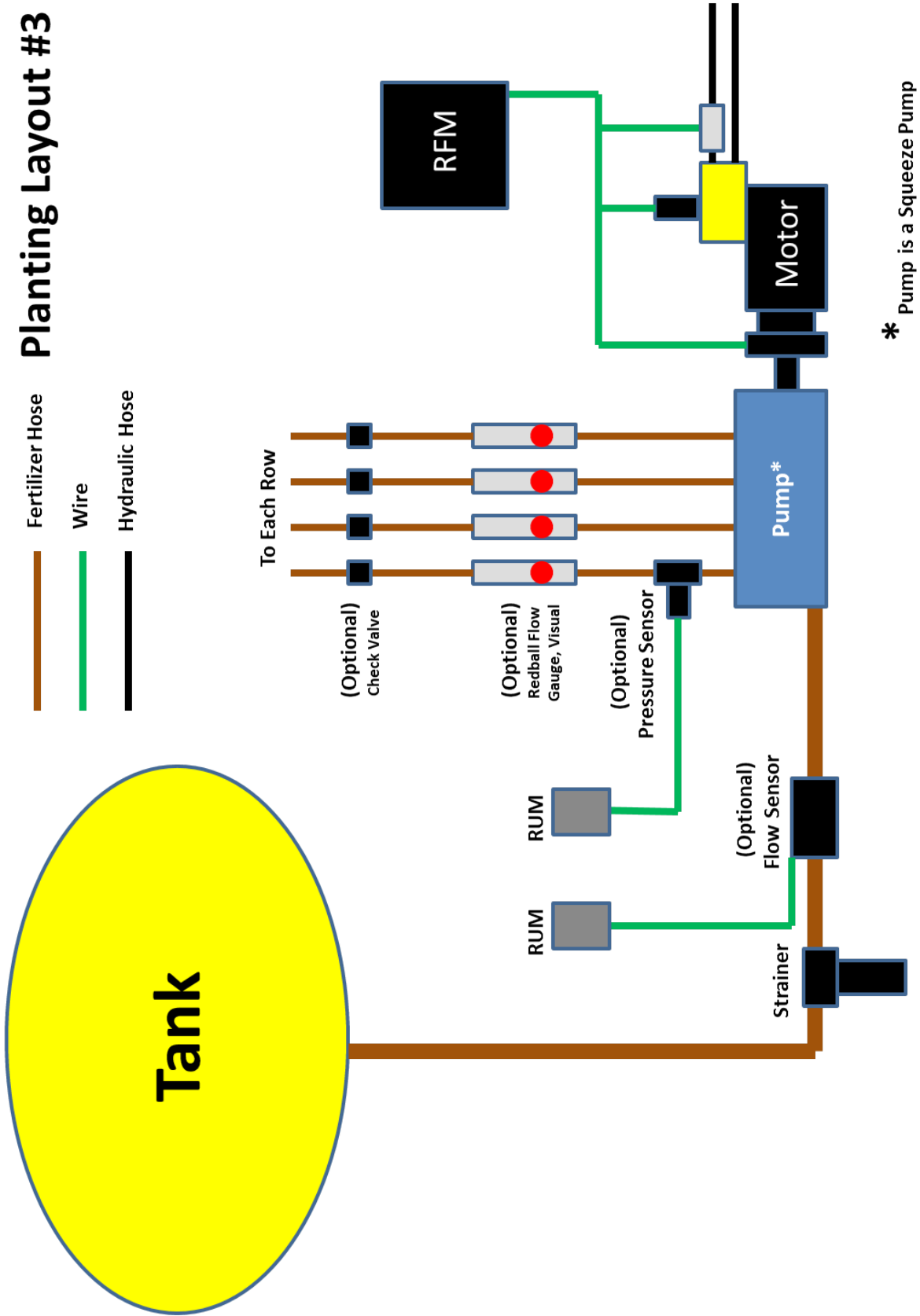

Full System Layouts (Sidedress)

SideDress Layout #1

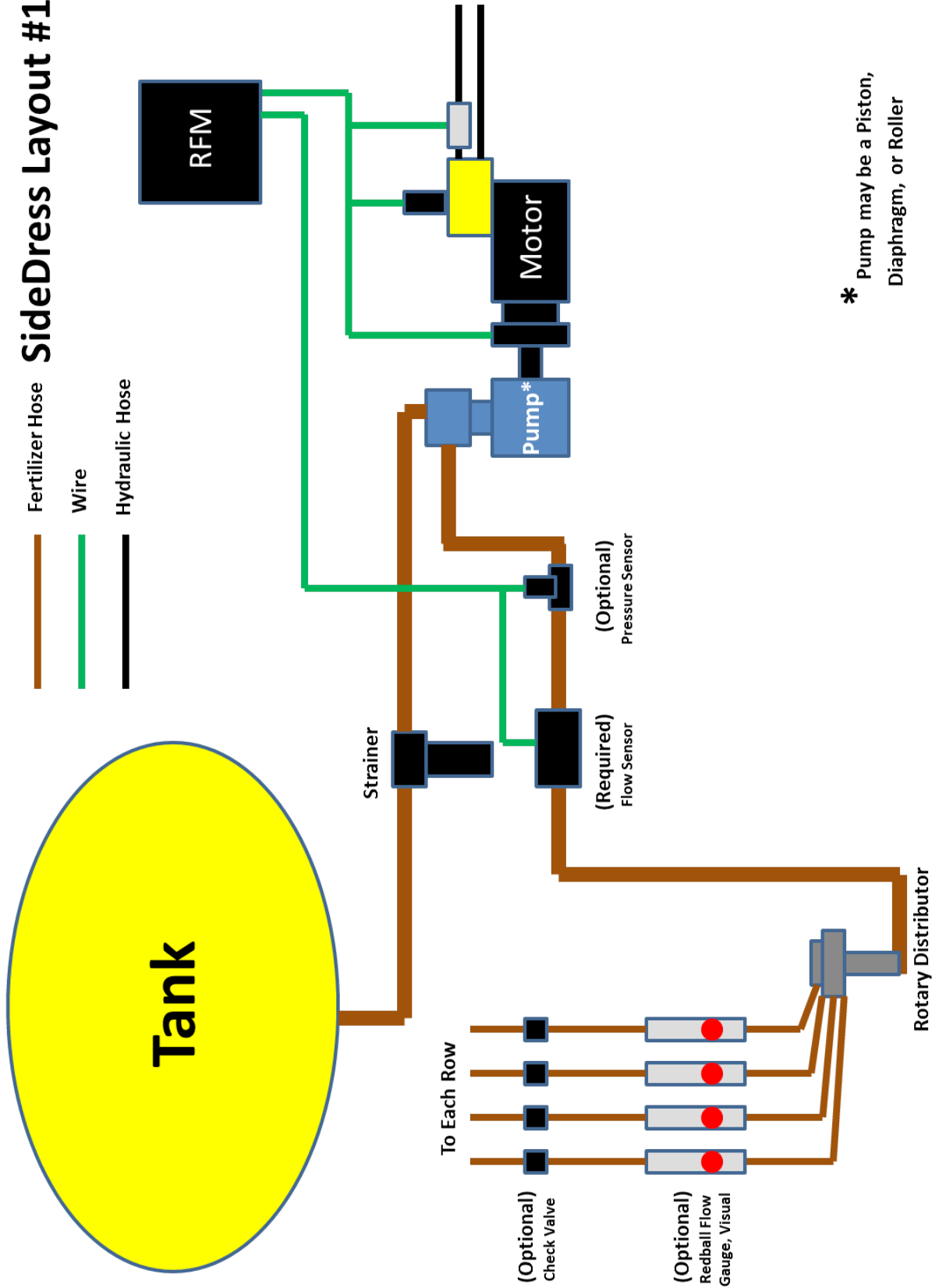

Full System Layouts (Sidedress)

SideDress Layout #2

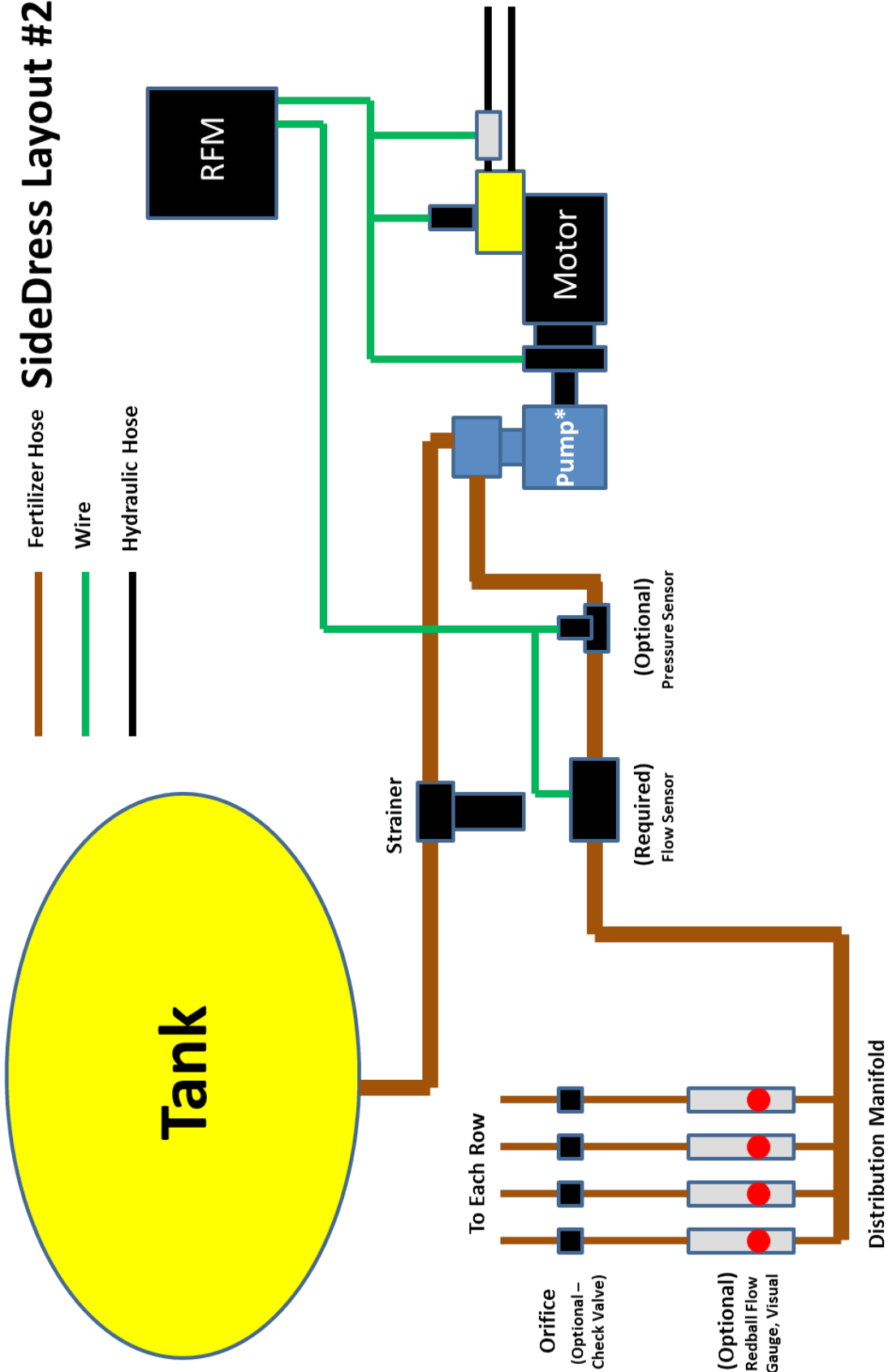

* Pump may be a Piston, Diaphragm, or Roller

Setup and Operation (Planter)

Planting Setup

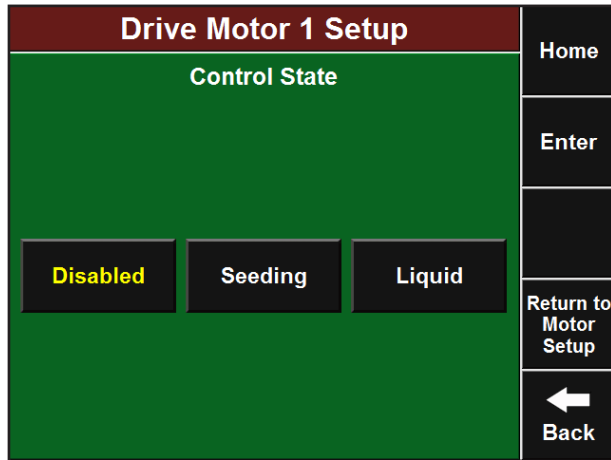

Motor Setup

Setup for liquid control motors can be accessed from both the standard motor setup screen for RowFlow or by going to Setup-Systems-RF Liquid. Select the correct Drive Motor that is driving the liquid pump and press Liquid. Select the correct motor brand and then enter the default rate at which you would like your product to be applied and then press Enter. Enter the maximum speed (in RPM's) for the liquid pump as defined by the pump's manufacturer specifications and then press Enter.

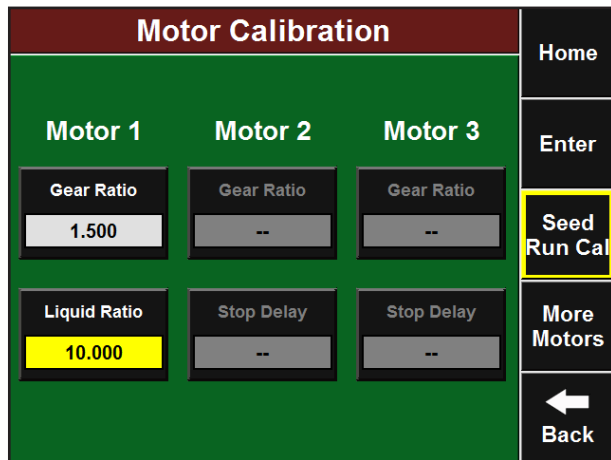

Motor Calibration

Liquid motor calibration is accessed from the same motor setup screen. Press Motor Calibration at the top and then press the Gear Ratio button. Enter the gear ratio calculated using the formula provided on this page and then press Enter. If the Drive Motor is directly coupled to the liquid pump, the Gear Ratio will be "1". Press the Liquid Ratio button to open the liquid motor calibration screen. If you know the number of ounces of product produced by one pump revolution, type it here and press Enter. You may also do a Liquid Run Cal to get this number by pressing the button at the right side of the screen.

Setup and Operation (Planter)

Motor Calibration

Prepare to Plant

- Hydraulic Pressure to Motor
- Liquid to Pump
- Output of Pump captured in a bucket

Press to Continue

NOTE:
Adjust the number of revolutions (on the right) if the amount pumped is too small to be measured

Home

Number of Revs
10

Pump RPM
75

←
Back

Liquid Run Cal

Start by entering the Number of Revs you would like the pump to spin and enter the Pump RPM's that you would like to run the calibration with. Number of Revs and Pump RPM will vary based on the pump and the size of the container you have to catch the product. If you do not pump enough product to measure, you may need to increase these values. Once you have set those two values, press the Press to Continue button (be sure to have hydraulic pressure to the motor, liquid to the pump, a container for measurement). Lift and hold the two Auto-Load Switches until the calibration is complete and you are returned to the previous screen. Measure the output of the pump (in ounces) and divide by the actual number of pump revolutions listed in the box at the bottom of the screen. This is the number that should be entered at the top. Press Enter to complete.

RF Liquid Control

Variable Rate
Manual

Preset Application Rates

Gal / Acre
5.0

Home

+0.5 Adjust
5.0

0.0

0.0

PSI
0

Enter

-0.5 Adjust

0.0

0.0

Sensor Calibration

AutoMap Express

Spin Liquid Motor

0.0

0.0

Setup

1.0

0.0

-1.0

←
Back

Sensor Setup

Navigate to the RowFlow Liquid control page to setup the Flow Sensor and Pressure Sensor. This page can be reached by pressing the RF Liquid button from the Home screen or by going to Setup-Systems-RF Liquid (Control). Press Sensor Calibration and then enter the flow calibration value for the Flow Meter installed on your liquid system. The flow calibration value is stamped on the metal tag attached to the Flow Meter. Press Enter and then enter the Pressure Sensor Range (**200 psi for Precision Planting Pressure Sensor**). Press Enter again to finish the Sensor Setup.

Preset Application Rates

Set Point 1
0.0

Set Point 2
0.0

Set Point 3
0.0

Set Point 4
0.0

Home

Set Point 5
0.0

Set Point 6
0.0

Set Point 7
0.0

Set Point 8
0.0

Enter

Quick Adjust Flow
0.5

←
Back

Rate Presets and Quick Adjust

To setup preset rates or change the quick adjust values press Preset Application Rates. From this screen you can enter commonly used rates that you can jump to from the RowFlow Liquid Control page in the eight Set Point boxes. You may also set the value for which your manual rate adjustment increments in the Quick Adjust Flow box.

Setup and Operation (Planter)

Planting Operation

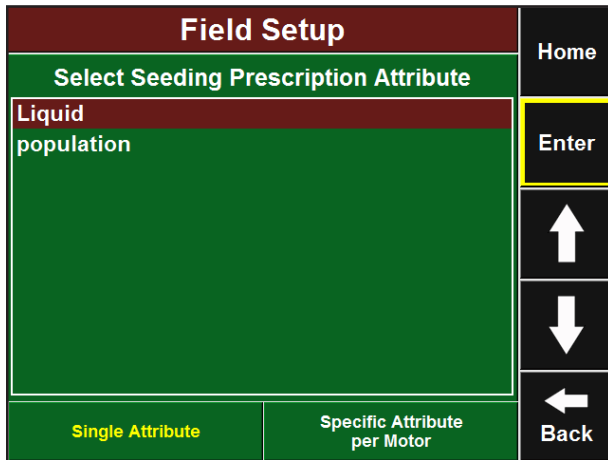

Field Prescription Selection

Select field from field selection menu (Setup-Field Name), and press the Prescription button to select the prescription with seeding rate and liquid rates. First choose the seeding attribute and press Enter. Select the liquid attribute, and press Enter.

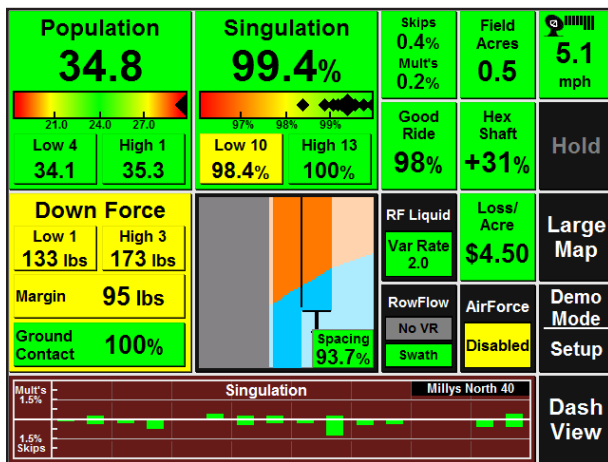

RowFlow Liquid Dashboard Buttons

The RowFlow Liquid Dashboard button is displayed by default when a liquid motor is setup. It functions similarly to the RowFlow Dashboard button. An additional dashboard button can be configured that will show both pressure and flow rates.



Cab Control Module Toggle Switches

The Master Plant Switch stops all motors, including the liquid motor. The toggle switch that correlates with the liquid motor will **NOT** stop it when flipped to the Off position. Holding up switches #2 and #4 to manually spin the seeding motors or to Auto Load the meters will **NOT** spin the liquid motor. To manually spin the liquid motor using Auto Load Switches, go to the RowFlow Liquid Control page and press the Spin Liquid Motor button.

Setup and Operation (Planter)

RowFlow Liquid Control Page

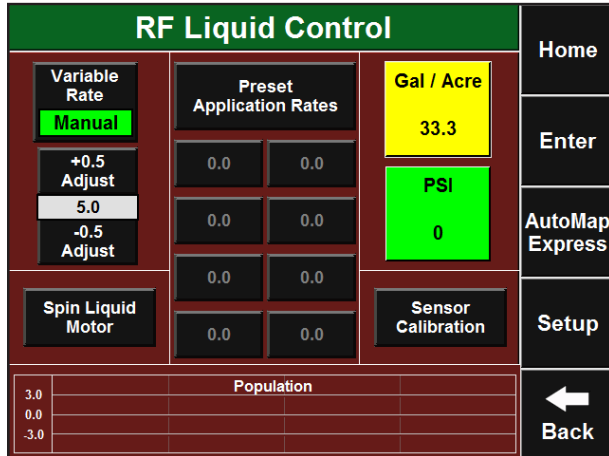

The RowFlow Liquid Control page can be accessed by pressing the *RF Liquid* button from the home screen or by pressing Setup-Systems-RF Liquid (Control). This page allows you to toggle between automatic variable rate liquid application and manual rate control by pressing the *Variable Rate* button near the top left. When in Manual mode, you may use the *+ Adjust* or *- Adjust* buttons to change the rate of liquid application. You may also select one of the Preset Application Rates from the center of the page. This page also shows you the Flow Rate and Pressure in the liquid system.

Automap Express

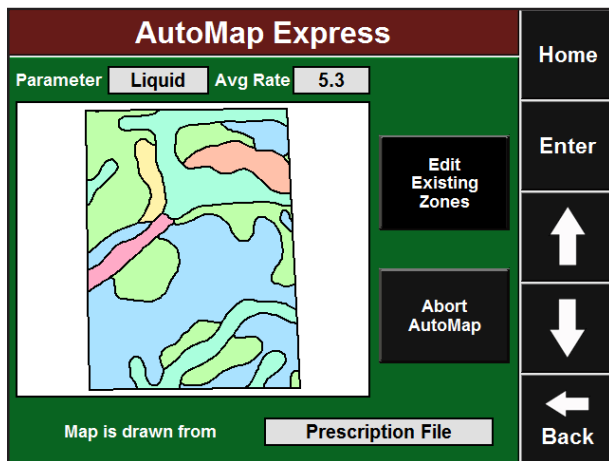

Automap Express will work with a liquid attribute just like it does with seeding. You can get to *Automap Express* through either the RowFlow Control page or the RF Liquid Control page. Press the Automap Express button on the right. If the Parameter box in the top left reads "population," press it and select Liquid. You may then edit the prescription accordingly.

If the prescription that is imported was not created in Automap, you may need to assign the correct parameter to each attribute. This is done by pressing the *Parameter* box from the Automap Express map screen and then selecting the parameter to the right of each attribute.

Diagnostic Page

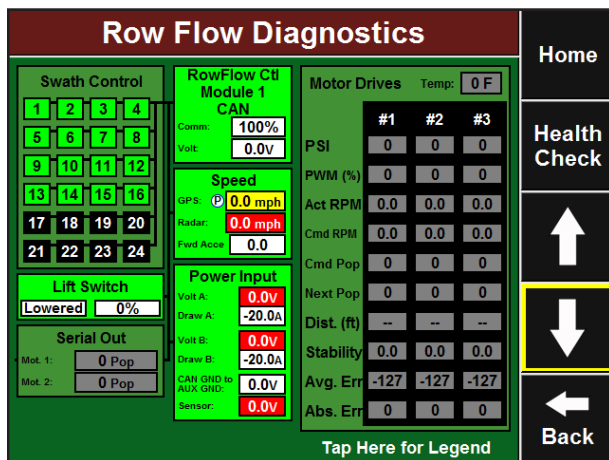

The RowFlow Diagnostic page (Setup-Diagnose-RowFlow) contains the diagnostic information for the RowFlow Liquid system. The hydraulic drive motor attached to the liquid pump will have all of the same diagnostics as that of a seeding motor when used in a planting application. However, *Cmd Pop* and *Next Pop* will have flow rates in Gallons per Acre (GPA). *Voltage / Current* and *Motor Stability* Health Checks will test the liquid system, where the others will not.

Setup and Operation (Planter)

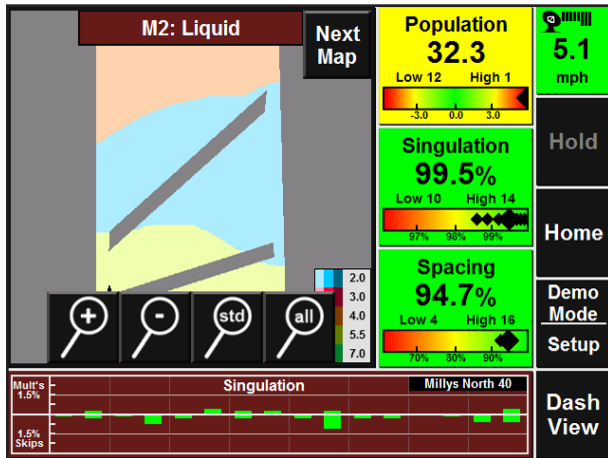

Dashboard – Large Map

While the Large Map is up on the Home Screen, you can toggle between a seeding map and liquid map by touching the map, bringing up the map menu. In the top right, press *Next Map* to toggle. Note that the zone colors will not change on the map, but the legend will. Coverage will still be based on seeding.

Miscellaneous

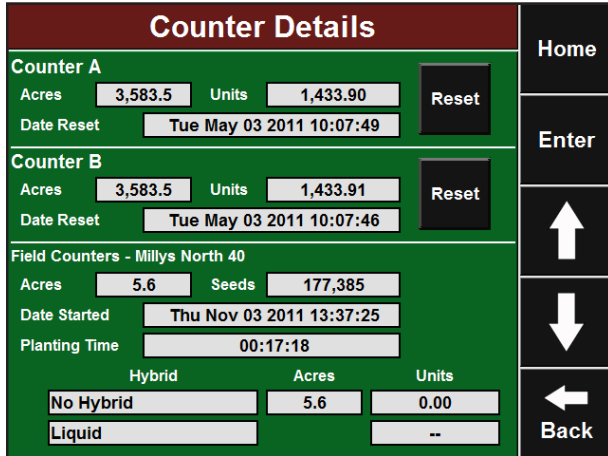

Total number of gallons is tracked per field and can be viewed by going to the Counter Details page.

Post-planting maps showing Applied Rate, Measured Pressure, and Commanded Rate will be available when exported with all other planting data.

Alerts specific to liquid application can be configured by going to Setup-Alerts-Liquid Alerts. Here you can configure colors and sounds for both the Home Screen and RowFlow Liquid Control page.

Setup and Operation (Sidedress)

Sidedress Setup

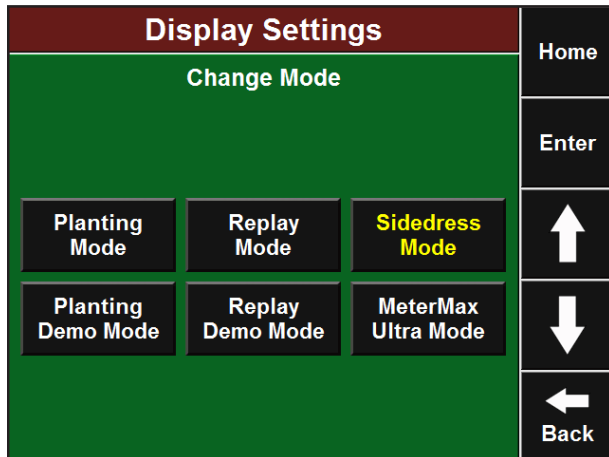

Sidedress Mode

The first step in setting up the 20/20 SeedSense for sidedressing is to put it into **Sidedress Mode** (Setup-Systems-Display-Display Mode). Select Sidedress Mode and press Enter. Your display is now ready for Sidedress Setup and Operation.

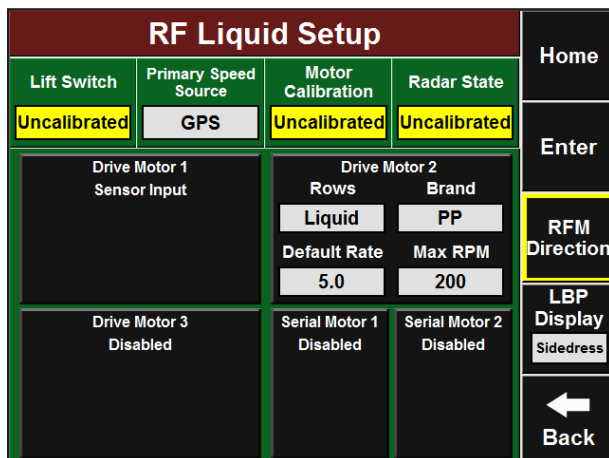

Lift Switch Calibration, Radar Calibration, and RFM Direction Setup

Sidedress Mode requires you to calibrate the lift switch on the sidedress applicator, calibrate applicator lift switch, and tractor radar. RFM Mounting Direction will also need to be specified. Refer to the RowFlow Operators Manual for these instructions.

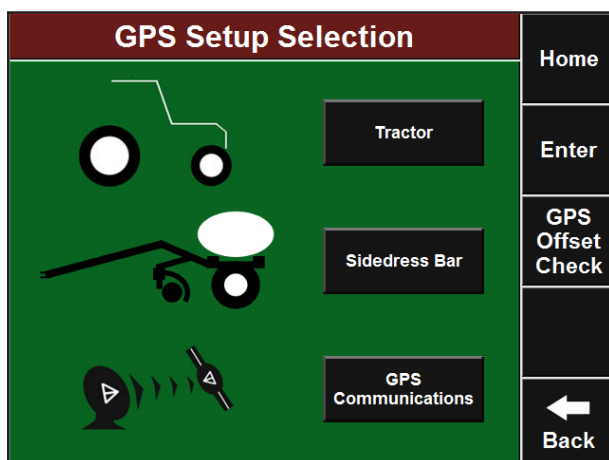

GPS Setup – Tractor

When entering Sidedress Mode for the first time, all GPS settings are reset to zero. Your Planting GPS settings are saved with Planting Mode, and your Sidedress settings will be saved with Sidedress Mode. Refer to RowFlow Operators Manual for setup of Tractor GPS.

Setup and Operation (Sidedress)

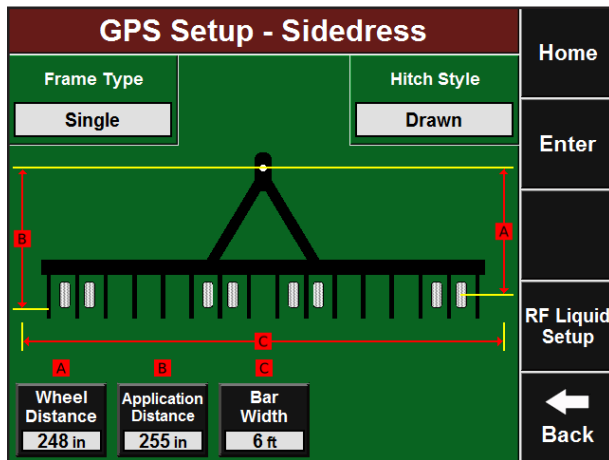

GPS Setup – Sidedress Bar

From the Home Screen, press Setup-Systems-GPS-Sidedress Bar to enter the GPS measurements for the bar. *Frame Type* is locked on Single. Press *Hitch Style* to select Drawn, 2-Point Pivot, or 3-Point and press *Enter*. The “A” measurement is measured from the pivot point at the hitch to the center of the transport wheels. The “B” measurement is measured from the pivot point at the hitch to the point of application. The “C” measurement is the effective width of the bar, not the actual measured bar width (leftmost point of application to the rightmost point).

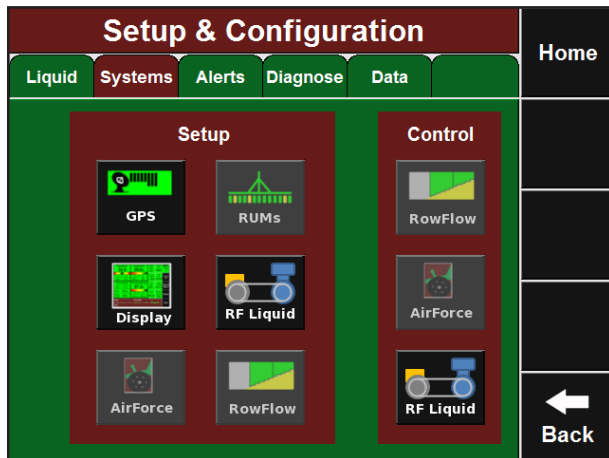

Motor Setup

Setup for liquid control motors can be accessed from the standard RowFlow motor setup screen for or by going to Setup-Systems-RF Liquid. Select Drive Motor #2 and press *Liquid*. Select the correct motor brand and then enter the default rate at which you would like your product to be applied and press *Enter*. Enter the maximum speed (in RPM’s) for the liquid pump as defined by the pump’s manufacturer specifications and then press *Enter*.

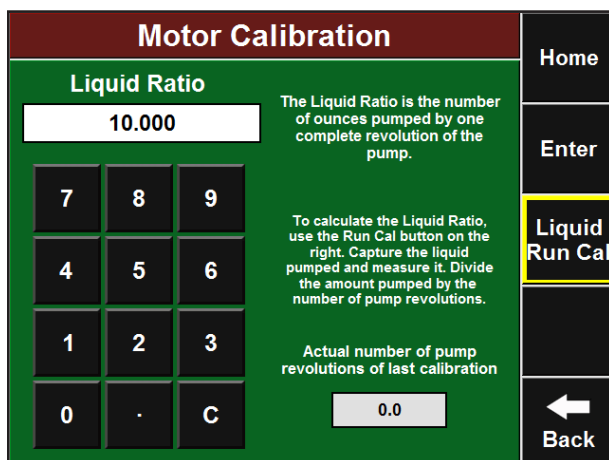

Motor Calibration

Liquid motor calibration is accessed from the same motor setup screen. Press *Motor Calibration* at the top and then press the *Gear Ratio* button. Enter the gear ratio calculated using the formula provided on this page and then press *Enter*. If the Drive Motor is directly coupled to the liquid pump, the Gear Ratio will be “1”. Press the *Liquid Ratio* button to open the liquid motor calibration screen. If you know the number of ounces of product produced by one pump revolution, you may enter it here and press *Enter*. You may also do a *Liquid Run Cal* to get this number by pressing the button at the right side of the screen.

Setup and Operation (Sidedress)

Liquid Run Cal

Start by entering the Number of Revs you would like the pump to spin and enter the Pump RPM's that you would like to run the calibration with. Number of Revs and Pump RPM will vary based on the pump and the size of the container you have to catch the product. If you do not pump enough product to measure, you may need to increase these values. Once you have set those two values, press the Press to Continue button (be sure to have hydraulic pressure to the motor, liquid to the pump, and some way to capture the output of the pump to measure). Lift and hold the two Auto-Load Switches until the calibration is complete and you are returned to the previous screen. Measure the output of the pump (in ounces) and divide by the Actual number of pump revolutions listed in the box at the bottom of the screen. This is the number that should be entered at the top. Press Enter to complete.

Motor Calibration	
Prepare to Plant	
<ul style="list-style-type: none"> - Hydraulic Pressure to Motor - Liquid to Pump - Output of Pump captured in a bucket 	
<div style="background-color: black; color: white; padding: 10px; width: fit-content; margin: 0 auto;">Press to Continue</div>	
<p>NOTE: Adjust the number of revolutions (on the right) if the amount pumped is too small to be measured</p>	
Home	
Number of Revs	10
Pump RPM	75
← Back	

RF Liquid Control			
Variable Rate	Preset Application Rates		Gal / Acre
Manual	0.0	0.0	33.3
+0.5 Adjust	0.0	0.0	PSI
5.0	0.0	0.0	0
-0.5 Adjust	0.0	0.0	Sensor Calibration
Spin Liquid Motor	0.0	0.0	
Population			
3.0			
0.0			
-3.0			
Home			
Enter			
AutoMap Express			
Setup			
← Back			

Sensor Setup

Navigate to the RowFlow Liquid control page to setup the Flow Sensor and Pressure Sensor. This page can be reached by pressing the RF Liquid button from the Home screen or by going to Setup-Systems-RF Liquid (Control). Press Sensor Calibration and then enter the flow calibration for the Flow Meter installed on your liquid system. The flow calibration is stamped on the metal tag attached to the Flow Meter. Press Enter and then enter the Pressure Sensor Range (200 for Precision Planting Pressure Sensor). Press Enter again to finish the Sensor Setup.

Preset Application Rates			
Set Point 1	Set Point 2	Set Point 3	Set Point 4
0.0	0.0	0.0	0.0
Set Point 5	Set Point 6	Set Point 7	Set Point 8
0.0	0.0	0.0	0.0
Quick Adjust Flow			
0.5			
Home			
Enter			
← Back			

Rate Presets and Quick Adjust

To setup preset rates or change the quick adjust values press Preset Application Rates. From this screen you can enter commonly used rates that you can jump to from the RowFlow Liquid Control page in the eight Set Point boxes. You may also set the value for which your manual rate adjustment increments in the Quick Adjust Flow box.

Setup and Operation (Sidedress)

Sidedress Operation

Population 0.0 Not Planting	Singulation --	Skips -- Milt's --	Field Acres 0.6	5.1 mph
Down Force Average -- Margin -- Ground Contact --	Good Spacing --	Good Ride --	Hex Shaft --	Replay Searching
		RF Liquid No Liquid	Loss/Acre --	Map
		RowFlow No RFM No RFM	AirForce Not Present	Demo Mode Setup
Variable Rate Manual	-0.5 Adjust	Target Rate 5.0	+0.5 Adjust	Gal / Acre 33.3
				PSI 0
				Dash View

Home Screen – Dashboard

Sidedress mode operates in a partial replay mode. You will see grayed out areas on the screen that is replayed planting data while you run. Areas not grayed out contain live data. This mode also gives access to two new 4x4 buttons: Planting Speed and Hybrids. These buttons can be configured through Setup-Systems-Display-Dashboard Buttons.

RF Liquid Control				Home
Variable Rate Manual	Preset Application Rates		Gal / Acre 33.3	Enter
+0.5 Adjust 5.0 -0.5 Adjust	0.0	0.0	PSI 0	AutoMap Express
Spin Liquid Motor	0.0	0.0	Sensor Calibration	Setup
Population				← Back
3.0				
0.0				
-3.0				

Sidedress Control

Sidedress Control can be done from either the RF Liquid Control page or the Dashboard Minichart while in Sidedress Mode. The RF Liquid Control page can be accessed by pressing the Dashboard Minichart. Manual variable rating is done in the same way as seeding and liquid planting application. Quick Adjust Rates and Preset Rates will need to be set up separately from liquid planting application. They are saved separately as well.

RF Liquid Control				Home
Variable Rate Manual	Preset Application Rates		Gal / Acre 33.3	Enter
+0.5 Adjust 5.0 -0.5 Adjust	0.0	0.0	PSI 0	AutoMap Express
Spin Liquid Motor	0.0	0.0	Sensor Calibration	Setup
Population				← Back
3.0				
0.0				
-3.0				

Cab Control Module

Holding up the #2 and #4 switches (Autoload switches) on the Cab Control Module while in Sidedress Mode will spin the liquid motors. Therefore, the *Spin Liquid Motor* button on the RF Liquid Control page is disabled.

Setup and Operation (Sidedress)

Miscellaneous

The coverage map on the home screen will be based on the rate being applied according to the Flow Sensor. Be aware that there may be a one to four second lag time when starting and stopping.

Post application maps will be available showing Applied Rate, Measured Pressure, and Commanded Rate, as well as some base data such as Tractor Speed. When data is exported, all data (planting and Sidedress) will be exported.

User adjustable alerts for sound and colors can be configured by going to Setup-Alerts. From this screen you can set the Pressure Sensor Upper Limit, Pressure Sensor Lower Limit, and Flow Sensor Limit from this screen. This affects both Dashboard Minichart and the RF Liquid Control Page.

Population 0.0 Not Planting	Singulation --	Skips -- Mult's --	Field Acres 0.2	7.0 mph
Down Force Average --		Good Ride --	Hex Shaft --	Replay Searching Boundary
Margin --		RF Liquid No Liquid	Loss/Acre --	Large Map
Ground Contact --		RowFlow No RFM No RFM	AirForce Not Present	Demo Mode Setup
Variable Rate Enabled	Current Rx 4.0	Next Rx 5.5	Gal / Acre 28.9	PSI 0
				Dash View